



TELEPHONE MAN OF AMERICA
1-866-770-4930
TELEPHONEMAN@TELEPHONEMANOFAMERICA.COM
Earning Your Business Every Step of the Way!
Specializing in Telecom Equipment of all Brands, Carrier Services,
Technician Services, Maintenance Agreements & Purchasing Excess
Telecom Equipment!

I will always do my best to match or beat any competitors bid!

TELEPHONE MAN OF AMERICA

Earning Your Business Every Step of the Way!

Specializing in Telecom Equipment of all Brands, Carrier Services, Technician Services, Maintenance Agreements & Purchasing Excess Telecom Equipment!

I will always do my best to match or beat any competitors bid!

| Local: 863-614-1900| Toll Free: 866-770-4930| Fax: 888-782-3072|

Email: telephoneman@telephonemanofamerica.com |

URL: www.TelephonemanOfAmerica.com| URL: www.shop.telephonemanofamerica.com |

Nortel Systems



Nortel Business Communications Manager 5.0 Upgrade Guide

BCM 5.0

Business Communications Manager

Document Status: **Standard**

Document Number: **NN40170-401**

Document Version: **01.05**

Date: **November 2009**

Copyright ©2009 Nortel Networks

All rights reserved.

The information in this document is subject to change without notice. The statements, configurations, technical data, and recommendations in this document are believed to be accurate and reliable, but are presented without express or implied warranty. Users must take full responsibility for their applications of any products specified in this document. The information in this document is proprietary to Nortel Networks.

LEGAL NOTICE

While the information in this document is believed to be accurate and reliable, except as otherwise expressly agreed to in writing NORTEL PROVIDES THIS DOCUMENT "AS IS "WITHOUT WARRANTY OR CONDITION OF ANY KIND, EITHER EXPRESS OR IMPLIED. The information and/or products described in this document are subject to change without notice.

Trademarks

Nortel, the Nortel logo, and the Globemark are trademarks of Nortel Networks.

Microsoft, MS, MS-DOS, Windows, and Windows NT are trademarks of Microsoft Corporation.

All other trademarks and registered trademarks are the property of their respective owners.

Contents

How to get help	5
Chapter 1	
Getting started	7
Applicable systems	7
What is new in BCM 5.0	7
Features not available	7
Using this upgrade guide	8
Pre upgrade	8
Upgrade	8
Post upgrade	8
Chapter 2	
Pre upgrade procedure	9
Important information to note before you attempt this upgrade	9
Pre upgrade tasks	10
Chapter 3	
Upgrading to BCM50 5.0, BCM450 5.0, and SRG50 5.0	13
Upgrading to SRG50 5.0	13
Performing the BCM 5.0, or SRG50 5.0 upgrade	13
Scheduling the upgrade	14
Verifying the time zone	15
Changing the DHCP server setting	15
Applying the keycode file	15
Performing the upgrade	18
Confirming the upgrade	22
Chapter 4	
Upgrading the BCM200/400 hardware	23
Upgrading a BCM200/400 to BCM450 5.0	23
Saving your current configuration using the Data Migration Manager	23
Preparing your configuration data for migration	25
Exporting your configuration data to the upgraded BCM450 5.0	25
Upgrading the BCM200/400 hardware	27
Chapter 5	
Post upgrade activities	31
Post upgrade tasks	31
Upgrading client applications	32

Installing Element Manager for BCM 5.0 and SRG50 5.0	33
Upgrading the manufacturing image to BCM 5.0	34
Troubleshooting	37
Common troubleshooting issues	37
If a step of the BCM 5.0 (or SRG50 5.0) upgrade fails	37
If your BCM 5.0 (or SRG50 5.0) system does not function properly	37
If your BCM 5.0 system generates a 31250 alarm after the upgrade	38
If your BCM 5.0 software update package does not appear on the Find Software Updates screen	38

How to get help

This section explains how to get help for Nortel products and services.

Getting help from the Nortel Web site

The best way to get technical support for Nortel products is from the Nortel Technical Support Web site:

www.nortel.com/support

This site provides quick access to software, documentation, bulletins, and tools to address issues with Nortel products. More specifically, the site enables you to:

- download software, documentation, and product bulletins
- search the Technical Support Web site and the Nortel Knowledge Base for answers to technical issues
- sign up for automatic notification of new software and documentation for Nortel equipment
- open and manage technical support cases

Getting help over the phone from a Nortel Solutions Center

If you do not find the information you require on the Nortel Technical Support Web site, and you have a Nortel support contract, you can also get help over the phone from a Nortel Solutions Center.

In North America, call 1-800-4NORTEL (1-800-466-7835).

Outside North America, go to the following Web site to obtain the phone number for your region:

www.nortel.com/callus

Getting help from a specialist by using an Express Routing Code

To access some Nortel Technical Solutions Centers, you can use an Express Routing Code (ERC) to quickly route your call to a specialist in your Nortel product or service. To locate the ERC for your product or service, go to:

www.nortel.com/erc

Getting help through a Nortel distributor or reseller

If you purchased a service contract for your Nortel product from a distributor or authorized reseller, contact the technical support staff for that distributor or reseller.

Chapter 1

Getting started

Use this document to upgrade from:

- Business Communications Manager 50 (BCM) 2.0 or BCM50 3.0 software to BCM 5.0 software
- Survivable Remote Gateway 50 (SRG50) 2.0 or SRG50 3.0 software to SRG50 5.0 software
- Business Communications Manager 450 (BCM450) 1.0 software to BCM450 5.0 software
- Business Communications Manager 200/400 4.0 hardware and software to BCM200/400 hardware and software



Survivable Remote Gateway (SRG)

An SRG50 system uses the same hardware and is based on the same software as a BCM system. When you apply the SRG keycode, only the SRG functionality is activated. Therefore, you use the same upgrade process to upgrade BCM and SRG50 systems.

Applicable systems

The upgrade applies to systems running:

- BCM 2.0
- BCM50 3.0
- SRG50 2.0
- SRG50 3.0
- BCM450 1.0
- BCM200/400 4.0

What is new in BCM 5.0

For a list of new features supported by BCM 5.0, see the *System Overview Guide*.

Features not available

There are no hardware changes from BCM450 1.0 to BCM450 5.0, from BCM50 2.0, or BCM50 3.0 to BCM50 5.0. Therefore, all new BCM 5.0 features function on a BCM50 upgraded to 5.0 or BCM450 upgraded to 5.0.

Using this upgrade guide

This section explains how to use the information in this guide.



Caution: Read all the instructions carefully before attempting the upgrade.

Pre upgrade

Perform the activities in [Chapter 2, “Pre upgrade procedure,”](#) on page 9 about prerequisites and pre upgrade tasks.

After you read this information and are certain that your system is ready to be upgraded, go to the [“Upgrade”](#) on page 8.

Upgrade

Perform the upgrade using the information in [Upgrading to BCM50 5.0, BCM450 5.0, and SRG50 5.0](#) on page 13, and [Upgrading the BCM200/400 hardware](#) on page 23.

This chapter describes:

- upgrading a BCM 2.0 or BCM 3.0 system
- upgrading an SRG50 2.0 or SRG50 3.0 system
- upgrading a BCM450 1.0 system
- upgrading a BCM200 or BCM400 to BCM 5.0
- step-by-step instructions to guide you through the upgrade process

Error messages might appear during the upgrade process. For more information, see [Appendix A, “Troubleshooting.”](#)

When the upgrade is complete, go to the [“Post upgrade”](#) on page 8.

Post upgrade

After a successful upgrade, go to [Chapter 5, “Post upgrade activities,”](#) on page 31.

This chapter describes:

- verification of upgraded data on your system
- manual entry of any parameters that are not automatically upgraded
- reinstallation of all client applications supported by BCM 5.0 on all desktop systems
- upgrading the Factory Image to 5.0.

Some or all of these activities might not apply to your system, but review them and perform the relevant activities.

Chapter 2

Pre upgrade procedure

Before you attempt the upgrade, review the following pre upgrade activities to determine if your system is compliant, and perform the indicated tasks to prepare your system for the upgrade.

If you are unable to correct an issue, contact technical support within your organization for help about resolving the issue.

Important information to note before you attempt this upgrade

Review the following information that is critical to the success of the upgrade process:

- **BCM system backup required:** You must have a complete and current backup of your BCM system (the system to upgrade) in case the upgrade fails. You can use this backup to restore your BCM system, and then you can attempt the upgrade again. You cannot use a BCM 2.0 or BCM 3.0 backup with BCM 5.0 software, or a BCM450 1.0 backup with BCM450 5.0 software.

If you are upgrading a BCM50 3.0 SRG50 3.0 system that was upgraded from BCM50 1.0 (or SRG50 1.0), Nortel recommends that you upgrade your manufacturing image to your current system software level. In the case of systems originally sold as BCM50 1.0, or SRG50 1.0, and later upgraded to 2.0, there is no means of upgrading the factory image to 2.0.

- **Retrieve Call Pilot Manager statistical data, if required (not applicable for SRG50):** Use Call Pilot Manager Reports section to retrieve and record all of the reports. Activity Reporter can be used to retrieve and record mailbox, hunt group, and CCR data.
- **Do not perform the upgrade through the dial-up modem:** Due to the size of the upgrade files, Nortel recommends that you do not attempt the upgrade through the dial-up modem.

Note on Using USB for Upgrades:

- For BCM50: Do not perform the upgrade through USB if upgrading a BCM50: Due to the size of the upgrade files, Nortel recommends that you do not attempt the upgrade through USB, as BCM50 systems use USB 1.1.
- For BCM450: BCM450 upgrades can be performed through USB.

Services are unavailable during upgrade: Once the you have downloaded the upgrade and the Apply phase begins your system is out of service until the upgrade is complete. The system services are down during that period, so ensure that you notify your users of the outage. Your system is fully functional after the upgrade is successful and the post upgrade activities are completed.

Upgrading an SRG50 system does not impact service to sets in Normal mode. However, if a WAN failure occurs during the upgrade process survivability is unavailable for branch office sets. Sets will be unable to connect to the server until the upgrade is complete.



Warning: Do not reboot, power cycle, or otherwise interrupt the BCM after reaching the Apply phase of the upgrade. This can cause catastrophic failure. Wait at least 1 hour after loss of contact with Element Manager to ensure a chance for a normal upgrade to complete.



Warning: Call Pilot Manager daily and cumulative statistics will be reset during the upgrade. Please retrieve and record this data before the upgrade.

Pre upgrade tasks

Perform the following pre upgrade tasks before you begin the upgrade:

- **Perform a backup of your BCM system:** Current settings are lost if a system failure occurs during the upgrade process. Use Business Element Manager (Administration > Backup and Restore > Backup) to back up all the data on your BCM system and store it in a location other than on the BCM system. This provides you with a backup of your most recent settings in the event of a system failure during the upgrade.

If you use Network Configuration Manager (NCM) to manage your networks, you can also use NCM to automatically obtain and store a backup of the BCM systems prior to the upgrade. For more information about NCM, see the appropriate NCM documentation.

- **Place the upgrade files in an appropriate location:** Your upgrade files are contained in either a zipped file or on DVD.

If your upgrade files are in a zipped file, unzip the files and place them in a location accessible to the management computer and the BCM system. Nortel recommends that you place all the upgrade files in a single directory. The supported upgrade file locations are:

- USB storage device (as indicated earlier, do not use this option for BCM50 upgrades)
- My Computer
- Network folder
- FTP server
- HTTP or HTTPS server

If your upgrade files are on DVD, you can perform the BCM or SRG upgrade directly from the DVD (or DVDs) - you do not need to copy the files to another location.

- **Obtain a valid keycode for the upgrade:** Before you begin the upgrade, you must have a valid keycode for your system. Use the Nortel keycode retrieval system (KRS) to view the existing features for your system and generate a BCM 5.0 or SRG 5.0 keycode file for your BCM or SRG with the required features. The generated keycode file must include the upgrade feature.



Warning: Do not attempt to add any features to your BCM system after you have downloaded the BCM 5.0 upgrade keycode until you have performed the upgrade. Any keycodes generated by KRS after the BCM 5.0 Upgrade keycode are intended for a BCM 5.0 system.

If you are upgrading an SRG system, the keycode must include the SRG feature in addition to the upgrade feature. Place this keycode file on the management computer that you are using to perform the upgrade.

For more information about keycodes, see the *Keycode Installation Guide*.

- **Verify management computer requirements:** Ensure that your management computer meets the following hardware and network requirements:
 - operating system (for Element Manager): Windows XP Professional SP2, Citrix Presentation Server 4.0, Windows 2003 Server (All Editions), Windows Server 2008, or Windows Vista.
 - RAM: minimum 512 MB
 - a DVD-ROM drive, or sufficient hard disk space to download the patch files.
 - minimum screen resolution: 640 x 480 or greater (1024 x 768 recommended)
 - color display (256 colors or greater)
 - free space on your hard disk (at least 150 MB for Element Manager)—you require more hard disk space if you are hosting the upgrade files on your management computer
 - browser: Internet Explorer (IE) 7.0, or IE 8.0
 - a stable power supply for the management computer (Nortel does not recommend you perform the upgrade process from a laptop using only battery power)
 - USB stick of sufficient capacity - 2 GB or greater (as indicated earlier, the USB option should not be used for BCM50 upgrades).

Chapter 3

Upgrading to BCM50 5.0, BCM450 5.0, and SRG50 5.0

This section describes the steps to upgrade a BCM50 2.0 or BCM50 3.0 system to BCM50 5.0, a BCM450 1.0 to BCM450 5.0, and an SRG 2.0 or SRG50 3.0 system to SRG50 5.0. The upgrade processes for BCM 5.0 and SRG50 5.0 are almost identical. Any differences in the procedures are indicated in this document. If you have not already done so, read all the instructions in "[Pre upgrade procedure](#)" (page 9) before you continue with these instructions.

If you are upgrading a BCM50 1.0 or an SRG50 1.0 system, you will first need to upgrade to 2.0 or 3.0 before upgrading to 5.0.



Warning: Perform a data backup before you start the upgrade process. Perform a backup of your system before you attempt the upgrade. Store the information off the hard disk of the system. This ensures that you can restore your system if the upgrade is not successful after you run a Software Reset.

Upgrading to SRG50 5.0

The SRG50 system is a peripheral of the Communication Server 1000 (CS 1000) but leverages the BCM50 core software to act as a remote gateway for the Main Office. Because of this dependency, the recommended upgrade path for SRG50 leverages the BCM50 5.0 upgrade process but requires a keycode that includes the SRG feature in addition to the upgrade feature and any other features required by the system.

Performing the BCM 5.0, or SRG50 5.0 upgrade

The method you use to install the upgrade will affect the amount of time it takes for the process to complete.

The following table shows the approximate timings of major phases of the upgrade. The timings assume a dedicated, fast, non-congested network between the BCM system, Management Computer and any external data point (for example, an FTP server). The table shows only some of the more commonly used installation methods.

If scheduling the upgrade, ensure a sufficient gap between the download time and the apply time to permit the transfer to complete. The BCM system continues to provide normal service until the Apply phase is reached. Do not schedule the CFS patch (BCM 450 only); it may be applied at any time without impacting service.

Table 1 Approximate upgrade times (in minutes)

System type	Method	Download	Validation	Application	Post-reboot	Approximate Total Time	Factory image (Optional)**	Approximate Total Time
BCM50*								
	Online / My	20	5	32	9	65	60	125
	Online / FTP	12	5*	32	9	60	55	115
	Scheduled / FTP	8	3	20	9	40	37	77
BCM450								
	Online / My Computer	13	1	6	7	30	28	58
	Online / FTP	3	1	6	7	16	15	31
	Online / USB	2	1	6	6	14	13	27
	Scheduled / FTP	3	1	6	7	18	17	35
*Upgrading your BCM50 system using USB will take significantly longer than any of these times as it is only equipped with a USB 1.1 interface. Installing the upgrade using USB is therefore not recommended for BCM50 systems.								
** Do not upgrade the manufacturing image until you are sure that your BCM 5.0 system is functioning properly. After performing the image manufacturing upgrade, your system cannot revert back to its pre upgrade configuration.								

Perform the upgrade process through Element Manager. For more information about Element Manager, see the Administration Guide or the online Help within Element Manager.

If you encounter problems during the upgrade, see Troubleshooting on page 31. If the upgrade does not complete successfully, contact technical support for assistance in identifying the cause of the failure.

To perform the BCM 5.0 or SRG50 5.0 upgrade

- 1 Complete the pre upgrade tasks (see [“Pre upgrade tasks”](#) on page 10).
- 2 Verify that the time zone is set to a valid entry (see [“Verifying the time zone”](#) on page 15).
- 3 Apply the keycode for BCM 5.0 or SRG50 5.0 (see [“Applying the keycode file”](#) on page 15).
- 4 Perform the upgrade (see [“Performing the third step of the upgrade”](#) on page 18).

Scheduling the upgrade

Using Element Manager, you can schedule the steps of the upgrade to begin at a later time (Administration > Software Management > Software Updates > Scheduled Updates tab).

To schedule the steps of the upgrade, you must follow the same tasks described in "[Pre upgrade tasks](#)" (page 10).

For more information about scheduling upgrades, see *Nortel Business Communications Manager 5.0 Administration and Security* or the online Help within Element Manager.

Verifying the time zone

Before you attempt the upgrade, ensure that the time zone has not been set back to the default value. The upgrade does not proceed if the time zone is set to the default value for a new system.

To verify the time zone

- 1 Using Element Manager, connect to your BCM system.
- 2 Select **Configuration > System > Date and Time**.
- 3 Verify that the system time zone is set to the correct time zone for your region. Ensure it is not set to Factory Default.

Changing the DHCP server setting

This change applies only to the BCM50 and BCM50b main units running BCM50 2.0, BCM50 3.0 SRG50 1.0, SRG50 2.0, or SRG50 3.0 (it does not apply to the router versions of the main units: BCM50a, BCM50e, BCM50ba, or BCM50be).

In BCM50 5.0, you cannot set the DHCP server to Automatic as in earlier releases.

Before performing the upgrade, if your DHCP server is set to Automatic, you must change this setting to either Enabled - All Devices, Enabled - IP Phones Only, or Disabled.

If you do not change the DHCP server setting, the system assigns the default value of DHCP server Enabled - IP Phones Only.

To change the DHCP server setting

- 1 Using Element Manager, connect to your BCM50 system.
- 2 Select **Configuration > Data Services > DHCP Server > General Settings tab**.
- 3 From the DHCP server is list, select one of the available settings: **Enabled - All Devices** or **Enabled - IP Phones Only**.

Applying the keycode file

Before upgrading the BCM software to 5.0 you must apply the new keycode file containing the upgrade feature that you generated for your BCM system. The keycode file must include the upgrade feature and all other required features. For SRG systems, you must also select the SRG feature in addition to the upgrade feature and all other required features.

To apply the keycode file

- 1 Open Element Manager.
- 2 Select **Configuration > System > Keycodes**.

The Keycodes panel appears.

- 3 Click **Load File**.

The Open dialog box appears.

- 4 Select the keycode file for your system and click **Open**.

After the keycode is applied to the system, the Applied dialog box appears.



Warning: Do not reboot your BCM system at this time. Ignore any message your receive asking you to reboot.

Figure 1 BCM50 (or SRG50) keycode applied

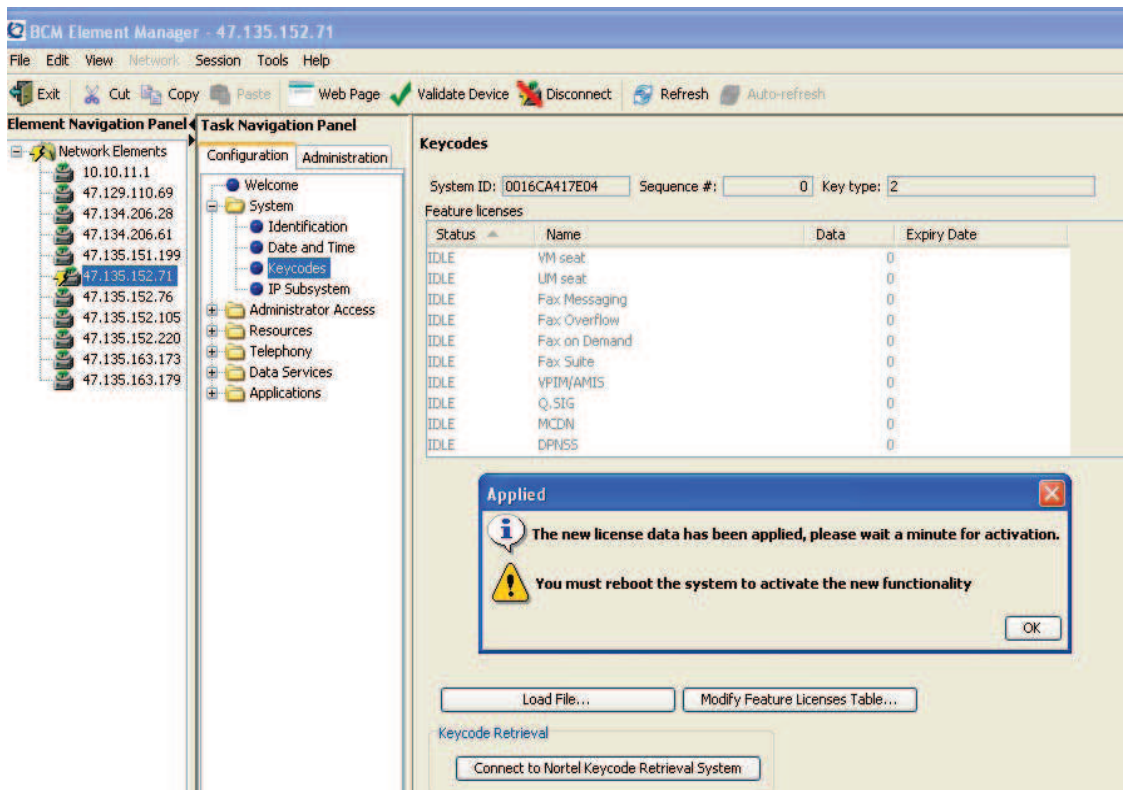
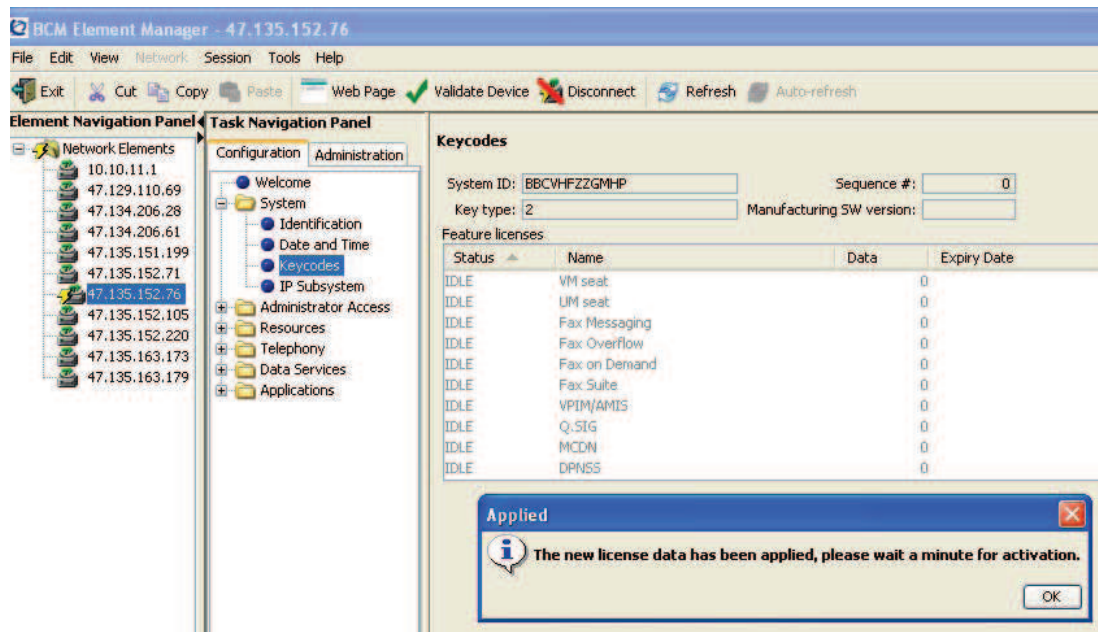

Figure 2 BCM450 keycode applied



- 5 Click **OK**. There is no need to wait after applying the keycode, you can proceed directly to the software upgrade.

Performing the upgrade

You can perform the upgrade using the BCM 5.0 version of Element Manager. If your upgrade files are on DVD, you can perform the upgrade directly from the DVD.



Warning: Do not reboot, power cycle, or otherwise interrupt the BCM after reaching the Apply phase of the upgrade. The BCM system is vulnerable during the upgrade process, and interruption can cause catastrophic failure.

To perform the upgrade

- 1 Using Element Manager, connect to the BCM450, BCM50, or SRG50 system you want to upgrade.
- 2 Select **Administration > Software Management > Software Updates > Updates in Progress**.
- 3 Click **Get New Updates**.

The Get New Updates dialog box appears.

- 4 From the **Retrieve from** list, select the location of the upgrade files.
- 5 Enter the required information in the dialog box.

USB Storage Device (not recommended for BCM50 or SRG50 systems):

- a In the USB Storage Device dialog box, browse to the directory of the upgrade files.
- b Click **OK**.

The Find Software Updates window appears with a list of updates.

My Computer:

- a In the **My Computer** dialog box, browse to the directory of the upgrade files. If you are installing from a DVD, browse to the DVD ROM drive.
- b Click **OK**.

The Find Software Updates window appears with a list of updates.

Network Folder

- a** In the Network folder dialog box, enter the required information about the location of the upgrade files.

Enter the following information:

- Network folder—enter the IP address or host name of the network folder and the resource name. For example, enter <hostname>\<resource>.
- Directory—enter the network folder resource name.
- User name—enter the user name associated with the shared folder.
- Password—enter the password of the user.
- Directory—enter the path to the subdirectory of the network folder (optional).

- b** Click **OK**.

The Find Software Updates window appears with a list of updates

FTP Server

- a** In the FTP Server dialog box, enter the required information about the location of the upgrade files.

Enter the following information:

- FTP Server: IP address or hostname
- User name: Valid user account for the ftp server you are connecting to.
- Password: Valid password associated with the user account.
- Directory: The remote path to the upgrade files relative to your home directory.

- b** Click **OK**.

The Find Software Updates window appears with a list of updates.

HTTP Server

- a** In the HTTP Server dialog box, enter the required information about the location of the upgrade files.

If you are using an HTTPS server, you must select **Use HTTPS** and enter the following information in the appropriate fields:

- User name: Valid user account for the ftp server you are connecting to.
- Password: Valid password associated with the user account.
- Directory: The remote path to the upgrade files relative to your home directory.

- b** Click **OK**.

The Find Software Updates window appears with a list of updates.

Figure 3 BCM50 (or SRG50) Find Software Updates screen

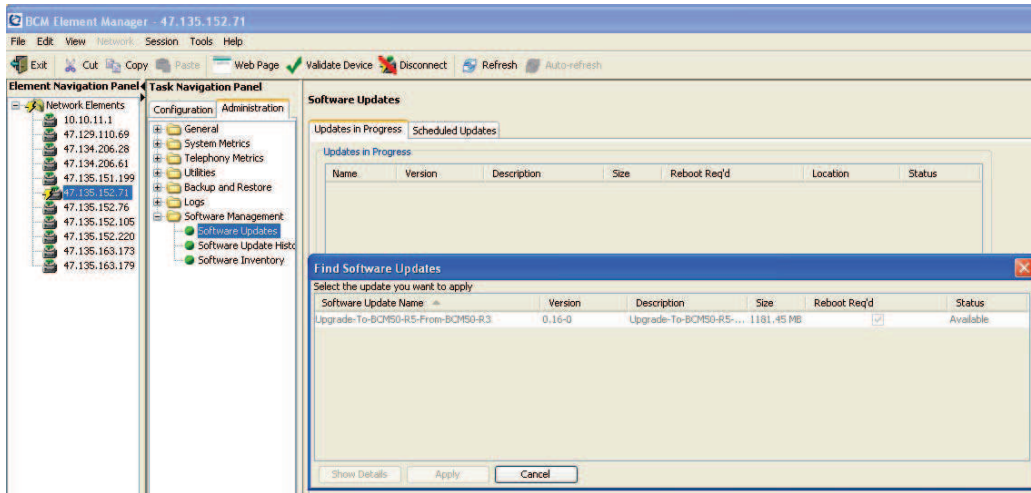

Figure 4 BCM450 Find Software Updates screen (BCM450.R100.CFS patch selected)

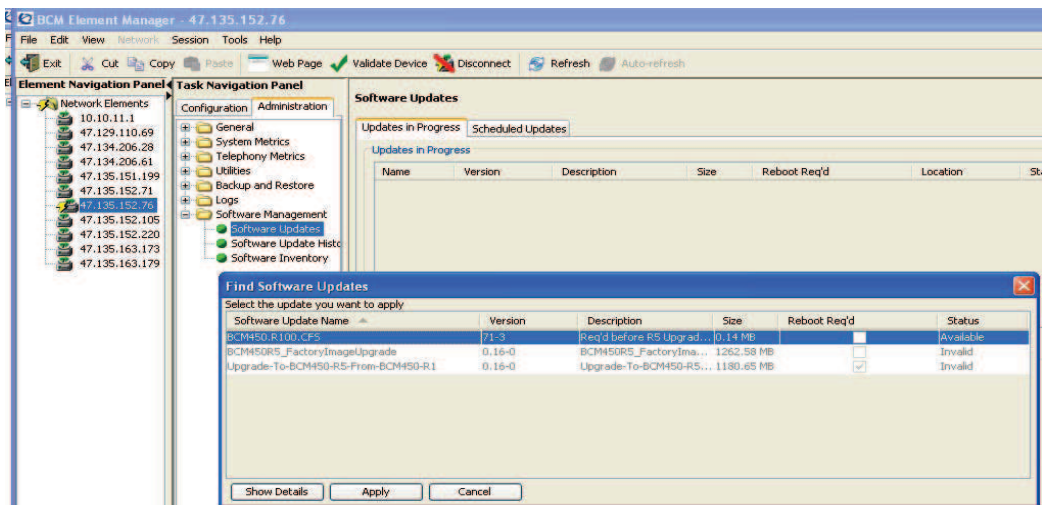
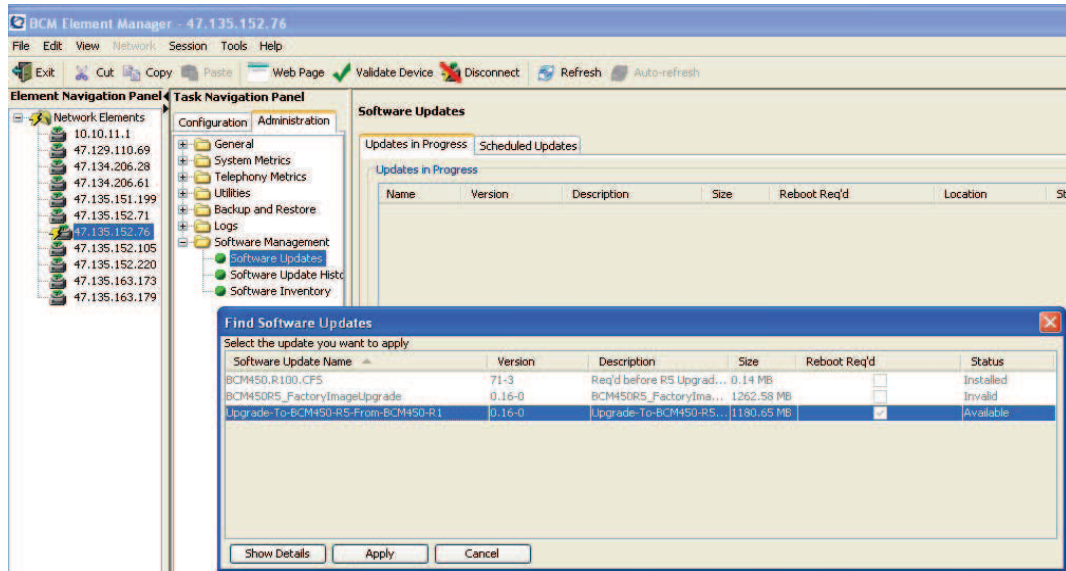

Figure 5 BCM450 Find Software Updates screen (BCM450 5.0 software upgrade selected)



- 6 In the Find Software Updates window, select the appropriate update for your system. If you are upgrading a BCM450 system and you have not applied the latest Smart Updates, you must first install the patch called BCM450_R100.CFS before installing the 5.0 upgrade package. If you have installed the latest Smart Updates, the status shows Obsolete.
- 7 To view details about the update, click **Show Details**.

The Details for Update window appears with details about the update. Click **OK** to close the details window.

- 8 Click **Apply** to apply the update.

A confirmation dialog box appears.

- 9 Click **Yes** to apply the upgrade.

The system automatically downloads, verifies, and applies the upgrade. This can take up to 65 minutes if upgrading a BCM50 system (up to 20 minutes for the download, 45 minutes to validate and install), and approximately 15-30 minutes if upgrading a BCM450 system (3-15 minutes to download, up to 15 minutes to validate and install), depending on your method of installing the patch. If you are applying the BCM450.R100.CFS patch, this process should take less than a minute, and the system will not reboot. After the upgrade is complete, the Software Update Complete confirmation window appears. The system automatically reboots and a dialog box appears stating that Element Manager is disconnected from the BCM50 system. Do not attempt to log back into Business Element Manager for approximately 10 minutes after the reboot.

10 Click **Ok**.

11 If you are upgrading a BCM450 system and have just applied the BCM450.R100.CFS patch, repeat [step 6](#) through [step 10](#) with the BCM450 5.0 software upgrade.

Confirming the upgrade

After you complete the upgrade you can confirm that your system is running BCM 5.0.

To confirm the upgrade

- 1** In Element Manager, select **Administration > Software Management > Software Update History**.
- 2** In the Software Update History list, verify that applicable updates are applied.
- 3** In Element Manager, select **Administration > Alarms**. An alarm will be displayed with the description “BCM successfully upgraded to software release R5.” This alarm will only appear when the BCM is booted for the first time with 5.0 installed. If the system is rebooted later, the alarm will no longer appear.
- 4** In Element Manager, select **Administration > Alarms**. A 31250 alarm will appear if you have not yet upgraded the manufacturing image,
- 5** Allow the newly upgraded BCM 5.0 system to run for up to 30 minutes, and verify that the system is operating properly.
- 6** Optionally, apply the BCM 5.0 factory image software update to the system. Refer to the section [Upgrading the manufacturing image to BCM 5.0](#) for more information.

Chapter 4

Upgrading the BCM200/400 hardware

This section describes the steps to upgrade a BCM200 or BCM400 system to BCM450 5.0.

Upgrading a BCM200/400 to BCM450 5.0

You can upgrade an existing BCM200 or BCM400 system to BCM450 5.0 with a hardware upgrade. The upgrade kit includes a new Chassis Interface card (CIF), a new BCM450 Base Function Tray, and a hard drive pre-loaded with the BCM450 5.0 software. You can also save and import your current BCM200 or BCM400 settings to the upgraded BCM450 5.0. You will still have to install the new client software and the new Business Element Manager for BCM 5.0.

The following data is not maintained when upgrading a BCM200 or BCM400 system:

- Call Pilot data:
 - Report Data
 - Off Premise Notification
 - Outbound Transfer
 - Mailbox Standard and Personalized Greetings
 - Personal Attendant
 - Fax Settings
 - Call Forward
 - Message blocking
 - Mailbox passwords
- User Accounts: All user account passwords will be reset to the system default (PlsChgMe!)
- IVR: Only IVR configuration data is migrated. All customized files must be re-imported.

Saving your current configuration using the Data Migration Manager

The Data Migration Manager (DMM) is a Java-based application that allows you to save your current BCM200/400 configuration prior to a hardware upgrade. This data can be reapplied to the upgraded BCM450 5.0 system.

The DMM can be downloaded from www.nortel.com, or from the BCM web page.

To save your current configuration data

- 1 Start the DMM tool and go to **File > Import and Export**.

The Import and Export Dialog appears.

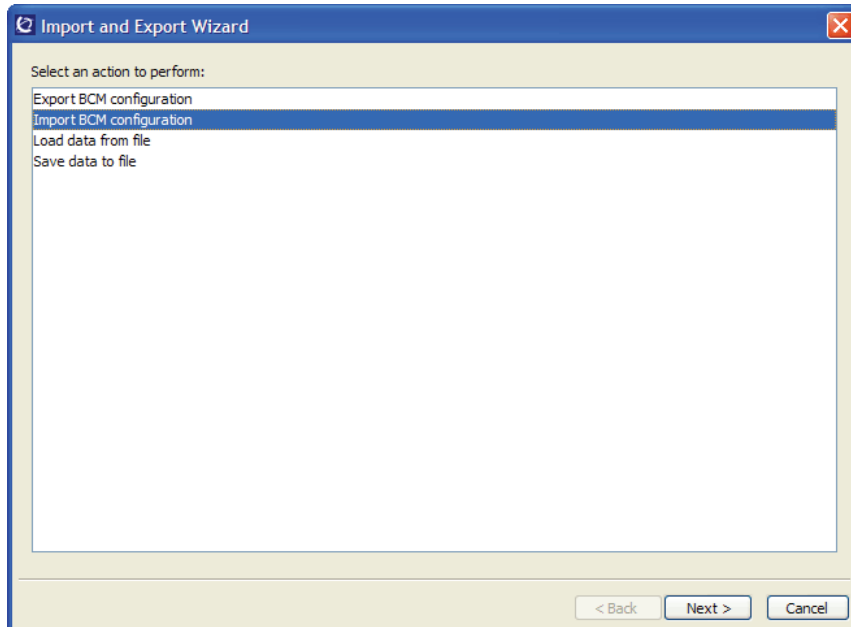

- 2 3. Select **Import BCM Configuration**.
- 3 Click **Next**.
- 4 Select **BCM** from the System Type field.
- 5 Click **Start**.
- 6 Enter the BCM IP address and your login credentials.

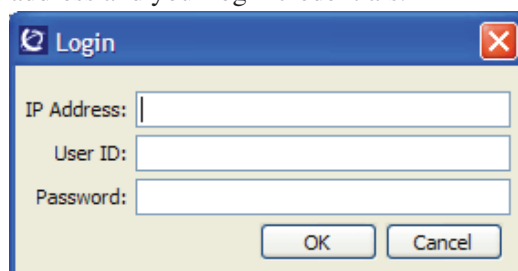

- 7 Click **OK**.

System makes appropriate connections and performs data retrievals. A reporting dialog is presented as the tool processes the request. When the request completes, you can save a report (in HTML format) for future reference.

Preparing your configuration data for migration

This operation must be executed prior to export of the data to a target. This operation gathers information about your target system and adjusts the export data to be received by the new BCM450.

To prepare your data for migration

- 1 Start the DMM and click **Prepare Data for Device**, under **Operations**.

The **Operations: Prepare Data for Device** pane appears.

- 2 Select BCM450 from the **Target Device Type** field.
- 3 Enter the number of Digital Sets.
- 4 Enter the number of Analog Sets.
- 5 Enter the number of Trunks.
- 6 Click **OK**.

Exporting your configuration data to the upgraded BCM450 5.0

After you have prepared the data for export, and upgraded your BCM hardware, you can export your configuration data to the newly upgraded BCM450 5.0 system.

To export your configuration data

- 1 Start the DMM tool and go to **File > Import and Export**.

The Import and Export Dialog appears.

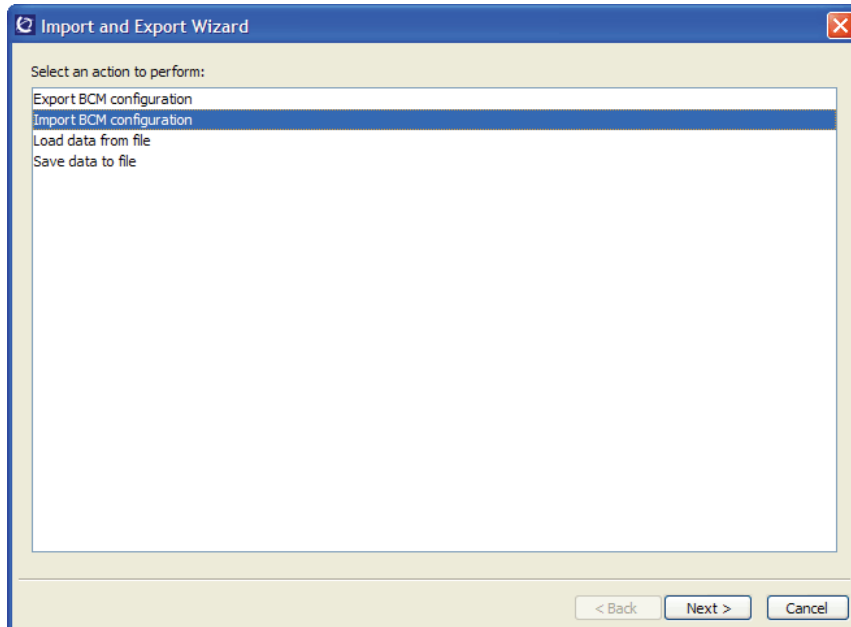

- 2 Select **Export BCM Configuration**.
- 3 Click **Next**.
- 4 Select BCM data to export and click **Start**.
- 5 Choose the components to export, or click **Select All** to export all your data.
- 6 Click **Next**.
- 7 Enter the BCM IP address and your login credentials.

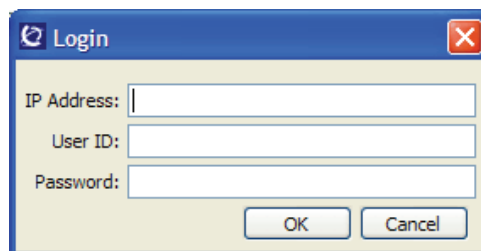

- 8 Click **Ok**.

System makes appropriate connections and performs data retrievals. A reporting dialog is presented as the tool processes the request. When the request completes, you can save a report (in HTML format) for future reference.

Upgrading the BCM200/400 hardware

Use the following procedures to upgrade your BCM400 or BCM200 system to BCM450 5.0.



Warning: Perform the upgrade on a clean, static-free surface. Use a wrist grounding strap to prevent damage to the hardware from static discharge.

To upgrade the BCM400 hardware

- 1 Save your current configuration data using the DMM. For more information, see [Saving your current configuration using the Data Migration Manager](#) on page 23.
- 2 Turn off the BCM and disconnect it from the power source.
- 3 Disconnect all cabling from the BCM.
- 4 Open the unit top cover.
- 5 Remove the Base Function Tray (BFT). For more information, see *BCM200/400 Installation and Maintenance Guide*.
- 6 Remove the Advanced Function Tray (AFT). For more information, see *BCM200/400 Installation and Maintenance Guide*.
- 7 Remove the Hard Disk Drive Cage from the AFT
- 8 Remove HDD cable from IO card and remove from Chassis.
- 9 Disconnect the DS256 cables from the backplane.
- 10 Disconnect all cables from the IO card.
- 11 Remove the top-left (closest to the BFT slot) screw from the IO card. Loosen the bottom-left screw.

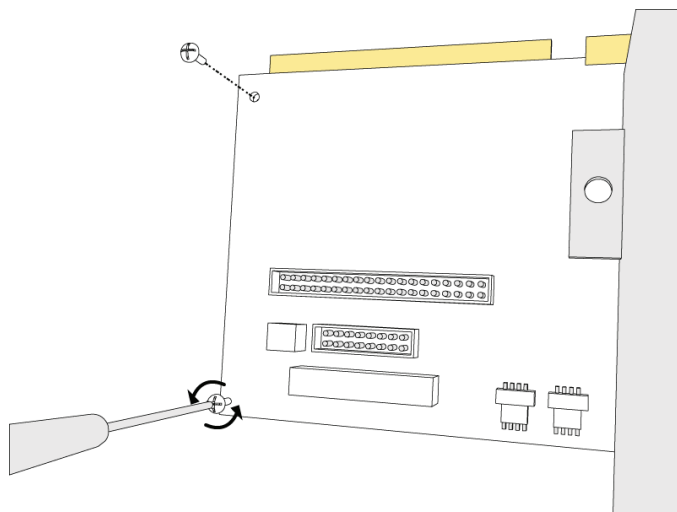

- 12 Place the new CIF card on top of the old IO card and slide it under the power supply. Ensure the groove on the bottom of the CIF is aligned with the loosened screw.

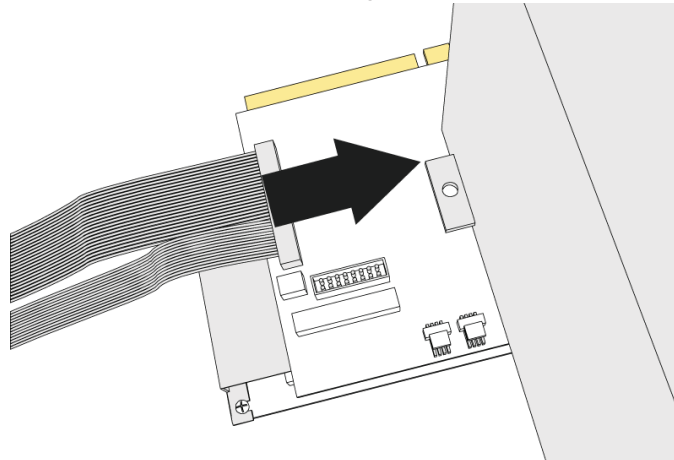

- 13 Replace the screw by passing it through both the CIF card and the old IO card.
- 14 Tighten the loosened screw on top of the groove on the CIF card.
- 15 Reconnect the cables to the CIF card. For more information about connecting cables to the CIF card, see *Nortel Business Communications Manager 450 Maintenance*.
- 16 Detach the HDD cables from the top of the chassis and cable tie them to the power cables going to the backplane
- 17 Replace the AFT.
- 18 Install the new BCM450 BFT with the new HDD pre-loaded with BCM 5.0.
- 19 Replace the top cover.
- 20 Remove the Media Bay Modules and reset the DIP switches to the default settings.
- 21 Replace the MBMs.
- 22 Reconnect power and turn on the BCM.
- 23 Connect to the BCM using Business Element Manager and apply any suggested patches.
- 24 Obtain and apply the new Keycode file
- 25 Using DMM, export your configuration data to the BCM450.
- 26 Verify that you configuration was exported correctly and test telephony connectivity by ensuring that the DNs on the old system are the same sets on the new system.

To upgrade the BCM200 hardware

- 1 Save your current configuration data using the DMM. For more information, see [Saving your current configuration using the Data Migration Manager](#) on page 23.
- 2 Turn off the BCM and disconnect it from the power source.
- 3 Disconnect all cabling from the BCM.
- 4 Open the unit top cover.

- 5 Remove the Base Function Tray (BFT). For more information, see *BCM200/400 Installation and Maintenance Guide*.
- 6 Remove the Hard Disk Drive door and tray.
- 7 Remove HDD cable from under the IO card (this may require removal of the IO card itself).
- 8 Disconnect the DS256 cables from the backplane.
- 9 Disconnect all cables from the IO card.
- 10 Remove the front-right (closest to the BFT slot) screw and the bottom-right screw from the IO card.

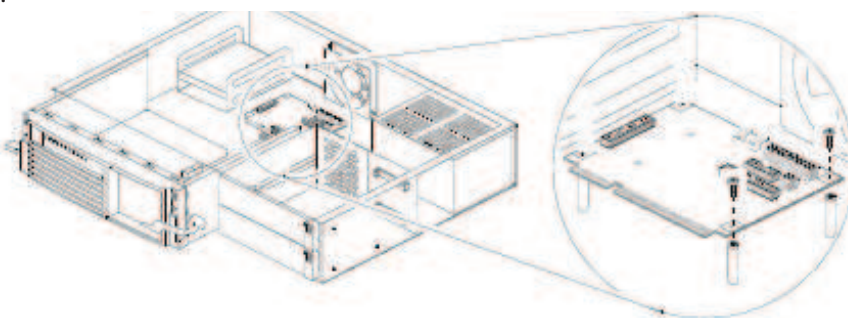

- 11 Place the new CIF card on top of the old IO card. Ensure the groove on the bottom of the CIF is aligned with the loosened screw.
- 12

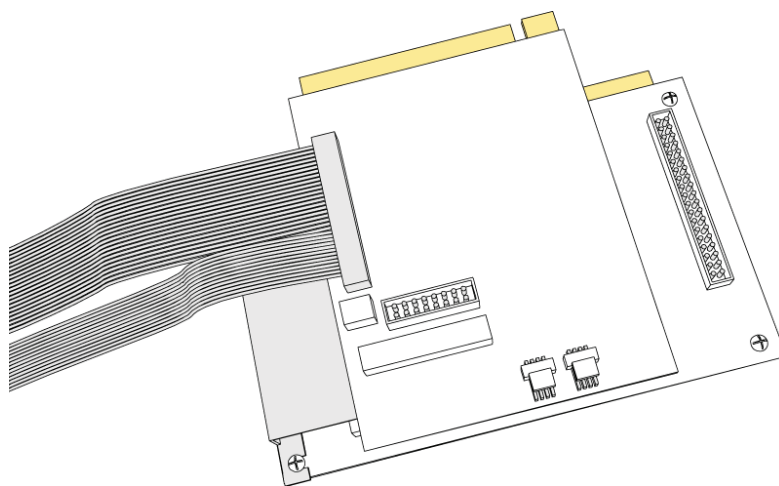

- 13 Replace the screw by passing it through both the CIF card and the old IO card.
- 14 Reconnect the cables to the CIF card. For more information about connecting cables to the CIF card, see *Nortel Business Communications Manager 450 Maintenance*.
- 15 Detach the HDD cables from the top of the chassis and cable tie them to the power cables going to the backplane
- 16 Replace the HDD door.

- 17 Install the new BCM450 BFT with the new HDD pre-loaded with BCM 5.0.
- 18 Replace the top cover.
- 19 Remove the Media Bay Modules and reset the DIP switches to the default settings.
- 20 Replace the MBMs.
- 21 Reconnect power and turn on the BCM.
- 22 Connect to the BCM using Business Element Manager and apply any suggested patches.
- 23 Obtain and apply the new Keycode file
- 24 Using DMM, export your configuration data to the BCM450.
- 25 Verify that you configuration was exported correctly and test telephony connectivity by ensuring that the DNs on the old system are the same sets on the new system.

Chapter 5

Post upgrade activities

The following section contains activities that you must perform after the upgrade is complete. You may not need to perform all of these activities. Not all systems use all the functions listed.

You must manually configure the items that were not preserved during the upgrade to BCM 5.0 or SRG50 5.0.

Post upgrade tasks

After performing the upgrade to BCM 5.0 (or SRG50 5.0), perform the following tasks:

- **Verify data was correctly preserved:** Use Element Manager to verify that your system data was correctly preserved.
- **Test your upgraded BCM 5.0 system:** You can perform several tests to confirm that your system is functioning properly. For more information about testing the system, see *Nortel Business Communications Manager 50 5.0 Installation and Maintenance Guide*, or *Nortel Business Communications Manager 450 5.0 Installation-System*.
- **Back up data:** As soon as you confirm that the system is operating as expected, perform a backup of all data, using Element Manager (Administration > Backup and Restore). This data is now your current backup.



Warning: Do not store the backup on the BCM system. Store it externally in case you have to perform a Software Reset.

- **Upgrade client applications:** After you upgrade your BCM system, you must upgrade the BCM client applications on each client computer (see [“Upgrading client applications” on page 32](#)). The BCM client applications must be compatible with the BCM software. The new versions of the client applications are available from the BCM 5.0 Web page. This is not necessary for SRG50 5.0 systems.
- **Install Business Element Manager for BCM 5.0 or SRG50 5.0:** After you have completed the upgrade, install the latest version of Business Element Manager. For more information, see [“Installing Element Manager for BCM 5.0 and SRG50 5.0” \(page 33\)](#).
- **Verify your scheduled tasks:** Most of the scheduled tasks for your BCM system are preserved during the upgrade process. Verify that the scheduled tasks are properly preserved and reconfigure any tasks that are required on your system.
- **Configure new features:** If you want to use new features available in BCM 5.0, you must configure these features on your system. The new BCM 5.0 features are installed with default settings.

- **(Optional) Upgrade the manufacturing image to BCM 5.0:** Until you upgrade the manufacturing image, a Software Reset operation will result in the downgrade of you BCM to the currently installed manufacturing image, and the BCM 5.0 upgrade will need to be re-run. Install the new manufacturing image to avoid an accidental downgrade when the Software Reset feature is used once you are satisfied that your system is correctly running BCM 5.0. This step is not necessary when upgrading a BCM 200 or 400 system to BCM 5.0 as the new hard disk drive is installed with the correct manufacturing image.

Upgrading client applications

You must uninstall previous versions of the client applications before you install the new version.

Perform the following procedures to upgrade BCM client applications on each client computer. You must download the applications from the BCM Web page.

To uninstall a client application



Warning: Call Detail Recording

Do not uninstall earlier versions of Call Detail Recording when you install new versions.

- 1 On the client computer, click the **Start** button, select **Settings**, and click **Control Panel**. The Control Panel window appears.
- 2 Double-click the **Add/Remove Programs** icon. The Add/Remove Programs Properties dialog box appears.
- 3 From the list of installed programs, select the program to uninstall.
- 4 Click the **Change/Remove** button.

To install the new version of the client application

- 1 Open a Web browser and enter the BCM system IP address in the address bar. The Enter Network Password dialog box appears.
- 2 Enter the administrator user name and password:
If user names and passwords are still set to default, use these values:
User name: **nnadmin**
Password: **PlsChgMe!**
Or for client application download only:
User name: **nnguest**
Password: **nnguest**
- 3 Click **OK**.
The Welcome to BCM Web page appears.

- 4 From the **Welcome to BCM** Web page, click **Main** tab.
- 5 Click the **BCM** button
The **Applications** panel appears.
- 6 From the Applications panel, double click **User Applications**.
The **User Applications** window appears.
- 7 Select the application you want to install.
- 8 Click the download link and save the file.
- 9 Double click the install file and follow the onscreen instructions.

Installing Element Manager for BCM 5.0 and SRG50 5.0

You must use the BCM 5.0 version of Element Manager after you have performed the upgrade. The BCM 5.0 version of Element Manager is distributed with the upgrade files. You can use the latest version of Element Manager to manage all previous BCM systems that use Element Manager (BCM50 1.0, BCM50 2.0, BCM50 3.0, BCM450 1.0, BCM 4.0, SRG50 1.0, SRG50 2.0, SRG50 3.0, and SRG50 5.0). You need only one instance of Element Manager on your computer.



Warning: If you want to preserve your network elements tree, do not uninstall your current version of Element Manager. To preserve the tree, install the BCM 5.0 version of Element Manager over your current version. This installation detects your existing application files and preserves your network elements.

To install Element Manager for BCM 5.0 or SRG50 5.0

- 1 **Optional:** If you do not want to preserve your network elements tree, uninstall the previous version of Element Manager.
- 2 Open a Web browser and enter the BCM system IP address in the address bar.
The Enter Network Password dialog box appears.
- 3 Enter the administrator user name and password:
Default user name: **nnadmin**
Default password: **PlsChgMe!**
For the client application download:
Default user name: **nnguest**
Default password: **nnguest**
- 4 Click **OK**.
The Welcome to BCM Web page appears.

- 5 From the **Welcome to BCM** Web page, click **Main** tab.
- 6 Click the **BCM** button
The **Applications** panel appears.
- 7 From the Applications panel, double click **BCM Element Manager**.
- 8 Follow the on screen instructions to install Business Element Manager
- 9 Click the download link and save the file.

Upgrading the manufacturing image to BCM 5.0

After you perform a Software Reset on your BCM system, the system reinitializes the software to the factory default state, which is the software image installed during manufacturing or during a previous upgrade.

This means that if you perform a Software Reset, the upgraded BCM 5.0 system reverts back to the installed BCM manufacturing image. Therefore, to return to your BCM 5.0 system, you must perform the upgrade and migrate all customer data again.

To prevent these extra upgrade steps, you can upgrade the manufacturing image to BCM 5.0.

The manufacturing image upgrade does not stop any services and it does not require a reboot of the system. Performing this upgrade requires minimal system resources, however Nortel recommends that you perform the upgrade during a maintenance period.

The manufacturing image upgrade takes approximately 60 minutes depending on connection speed and the location of the software update files. You cannot remove the manufacturing image upgrade after it has been installed. The original manufacturing image is no longer available.

This step is not necessary for upgraded BCM200 or BCM400 systems, as the new hard drive is installed with the correct manufacturing image.



Warning: Do not upgrade the manufacturing image until you are sure that your BCM 5.0 system is functioning properly. After performing the manufacturing image upgrade, your system cannot revert back to its pre upgrade configuration.

To upgrade the manufacturing image

- 1 Obtain the software update files on DVD-ROM.
- 2 Copy the software update files to a single directory that is accessible to the BCM or SRG50 system.
- 3 Using Element Manager, connect to your BCM or SRG50 system.
- 4 Select **Administration > Software Management > Software Updates**.
- 5 Click **Get New Updates**.
- 6 From the **Retrieve from** list, select the location of the software update files.
- 7 Enter the required information in the dialog box.

USB Storage Device:

- a** In the USB Storage Device dialog box, enter the required information about the location of the software update files. Click **OK**.

My Computer:

- a** In the My Computer dialog box, enter the required information about the location of the software update files. Click **OK**.

Network Folder:

- a** In the Network folder dialog box, enter the required information about the location of the software update files. The information has the following parts:
 - Network folder—Enter the IP address or host name of the network folder and the resource name. For example, enter <hostname>\<resource>.
 - User name—Enter the user name associated with the shared folder.
 - Password—Enter the password of the user.
 - Directory—Enter the path to the subdirectory of the network folder (optional).
- b** Click **OK**.

FTP Server:

- a** In the FTP Server dialog box, enter the required information about the location of the software update files. The information has the following parts:
 - User name—Enter the user name associated with the shared folder.
 - Password—Enter the password of the user.
 - Directory—Enter the path to the subdirectory of the network folder (optional).
- b** Click **OK**.

HTTP Server:

- a** In the HTTP Server dialog box, enter the required information about the location of the software update files. If you want to use an HTTPS server you must enter the following information:
 - User name—Enter the user name associated with the shared folder.
 - Password—Enter the password of the user.
 - Directory—Enter the path to the subdirectory of the network folder (optional).
- b** Click **OK**.

- 8** In the Find Software Updates window, select the correct BCM 5.0 Factory Image depending on your system.
- 9** To view details about the update, click **Show Details**.
Click **OK** to close the details window.
- 10** Click **Apply** to apply the update.

The system automatically downloads, verifies, and applies the upgrade. This can take up to an hour depending on your system and the method of installing the patch. After the upgrade is installed, the Software Update Complete confirmation window appears.

After the operation finishes, a confirmation dialog box appears.

- 11** Click **Yes** to apply the update.

The system automatically applies the update. After the update is complete, the Software Update Complete confirmation window appears.

- 12** Click **Ok**.

The factory image update is complete.

Appendix A

Troubleshooting

This chapter provides information about troubleshooting the BCM 5.0 (or SRG50 5.0) upgrade process.

If you are not certain about how to deal with specific conditions, contact technical support for assistance. For more information about getting help, see [This section explains how to get help for Nortel products and services](#) on page 5. If you encounter an error, click the Show Details button for more information.

This chapter contains information about:

- [Common troubleshooting issues](#) on page 37

Common troubleshooting issues

The following sections describe general issues that prevent your BCM system from functioning properly.

If a step of the BCM 5.0 (or SRG50 5.0) upgrade fails

If a step of the BCM50 5.0 (or SRG50 5.0) upgrade fails, contact technical support for assistance in identifying the severity of the failure.

Correct the issue that caused the step of the upgrade to fail and attempt the upgrade again.

If your BCM 5.0 (or SRG50 5.0) system does not function properly

If your BCM (or SRG50) system does not function after the upgrade and the problem cannot be corrected by other troubleshooting methods, then complete the following steps to revert your system back to its pre upgrade status and attempt the upgrade again.

- 1 Use the reset switch or the Maintenance CLI to perform a Software Reset on your BCM (or SRG50) system to factory defaults. For details about performing a Software Reset, see *Nortel Business Communications Manager 5.0 Administration and Security* (NN40170-603).

If you did not upgrade the manufacturing image of your system, your system reverts back to the factory defaults of the software version before the upgrade (BCM50 2.0, BCM50 3.0, or BCM450 1.0). If you are upgrading an SRG50 system and have not upgraded the manufacturing image from the original BCM50 manufacturing image to the SRG50 manufacturing image, the system will revert to the BCM50 factory default.

If you did upgrade the manufacturing image of your system, then your system reverts to the BCM 5.0 factory defaults.

- 2 For SRG50 only, convert your BCM50 system to an SRG50 system. For more information about creating an SRG50 system, see the *Survivable Remote Gateway 50 Configuration Guide* and *Communication Server CS 2100 Configuration-Survivable Remote Gateway 50* (NN42200-500).
- 3 Restore the BCM (or SRG50) data to your system from the backup you created during the pre upgrade tasks.

The BCM (or SRG50) system is now back at the pre upgrade configuration. You can attempt the upgrade again.

If your BCM 5.0 system generates a 31250 alarm after the upgrade

This warning alarm indicates that you upgraded your system to BCM 5.0, but you have not upgraded the manufacturing image to BCM 5.0. The system generates this alarm every time the BCM 5.0 reboots.

This alarm does not affect the services running on the BCM 5.0 system, therefore it is not mandatory that you upgrade the manufacturing image.

To upgrade the manufacturing image to BCM 5.0, see [Upgrading the manufacturing image to BCM 5.0](#) on page 34.

If your BCM 5.0 software update package does not appear on the Find Software Updates screen

If your BCM 5.0 (or SRG50 5.0) software update package does not appear on the Find Software Updates screen, use the following steps.

- 1 If you are retrieving your software update package from a network folder, HTTP server, HTTPS server, SFTP server, or FTP server ensure that the specified path to the software update is correct.
- 2 If you are retrieving your software update package from a network folder, HTTP server, HTTPS server, SFTP server, or FTP server ensure that you have entered any authentication credentials (user name and password) correctly.
- 3 Ensure that you have the correct software update package. For example, if you are upgrading a BCM450 system, ensure you have the BCM450 5.0 software update package. If you are upgrading a BCM50 system, ensure you have the BCM50 5.0 software package.
- 4 Ensure that you have applied the BCM 5.0 upgrade keycode for your system.

